

### General Description

The 100 watt per channel, four-channel MA 4 amplifier achieves unparalleled power density, reliability and features in a space saving 1U, 19 inch rack mount chassis weighing only eight pounds (3.6 kg). A universal-voltage switching power supply provides near perfect Power-Factor, reducing peak currents to 1/3 compared to non power-factor-corrected supplies. A long list of unique features ranging from constant load power to built in automatic redundancy switching to advanced dynamics control, qualify the MA 4 for the most demanding fixed installation applications. The MA 4 excels in Music & Paging systems, small conference rooms and speech reinforcement applications requiring multiple amplifiers. Advanced dynamics control algorithms adapt to changes in temperature, load impedance and sensitivity setting. *The result is a truly plug-and-play amplifier that ensures excellent signal integrity at all times.*

### Features

- Universal voltage, power-factor-corrected power supply
- Very low inrush current
- 100 watts x 4 channels in 1U chassis
- Built-in load monitoring
- Remote fault reporting and redundancy switching
- Optional 4 channel 70/100 volt transformers in 1U chassis
- Adjustable high-pass filters and remote level controllable
- Advanced dynamics control adjusts for sensitivity setting, load Z and temperature

### Accessories

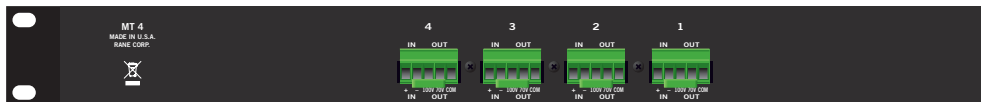

MT 4 Multichannel Transformer for 100V or 70.7V constant-voltage distribution.

VR 2 Volume Remote can control the level from within each zone.



Parameter	Specification	Conditions/Comments
Input impedance	10 kΩ	Each leg, differential, 1 kHz
Maximum input	+22 dBu	
Sensitivity range/resolution	+22 to +4 dBu	256 steps
Remote level control range/resolution	Attenuate only; 0 dB to -80 dB	Audio taper response, 256 steps
Fault flag in/out	Active 5V high-side drive, passive pull down.	NO Fault = +5V; Fault = 0V
Limiter	Oversampled instantaneous attack	3 dB per second decay
.....Load compensated	Limit set for 7.5 amps peak	Based on load Z
Compressor	50 ms rms detector	Threshold relative to limiter
.....Threshold	10 dB re peak dBFS	Rear panel dipswitch on/off
.....Attack	1.5 second	
.....Decay	3 dB per second	
.....Knee Span	10 dB	
Expander	Select on rear panel	rms detector
.....Threshold	-70 dBFS	
.....Attack	50 ms	Gain reduction release time constant
.....Decay	10 dB per second	Rate of gain reduction
High-pass filter	12 dB per octave, Butterworth	20, 40, 60, 80 Hz dipswitch select
Load sensing	2 to 16Ω normal	Green Load indicator <i>on</i>
.....Low load detect	Below 2Ω is low	Green Load indicator <i>flashing</i>
.....High load detect	Above 16Ω is high	Green Load indicator <i>off</i>
.....Min average power	3.3 watts average required for good load estimate	
Output		
.....Power	100 watts	3 to 8 Ω
.....Frequency response	20 Hz to 20 kHz	+0, -3 dB
.....Dynamic range	>90 dB	A-weighted, typical
.....THD+N	0.1% typ	100 watts into 4Ω, 20-20 kHz
.....Clock fundamental	310 kHz	<10 mV residual
.....Relay switching	Turn on mute, fault protection, redundancy switching	
Fan cooling	Temperature controlled, variable speed	Intake left side, exhaust right side
Heat load in Btu/hr		100 / 240 volts AC 50/60 Hz
.....Standby	10.2 / 13.3	
.....Run mode, no signal	112.3 / 95.5	
.....All channels driven	167 / 139	pink noise, average 1/8 <sup>th</sup> power, 4:1 crest
AC Mains	100 to 240 VAC	±10%, 50 or 60 Hz
PFC	100 kHz boost	
DC/DC	200 kHz forward	
Agency Listing: Safety	CB Scheme Report, UL, cUL (Canada)	IEC 60065, 7th Edition
EMI: CE		EMC directive 89/336/EEC
.....FCC	Part 15B	Class B Device
Construction	All Steel	
.....Size	1.75"H x 19"W x 9.25"D	(4.4 cm x 48.3 cm x 23.5 cm)
.....Weight:	8 lb	(3.6 kg)
Shipping: Size	4.5" x 20.3" x 13.75"	(11.5 cm x 52 cm x 35 cm)
.....Weight:	11 lb	(5 kg)

*All specifications typical unless otherwise noted.*

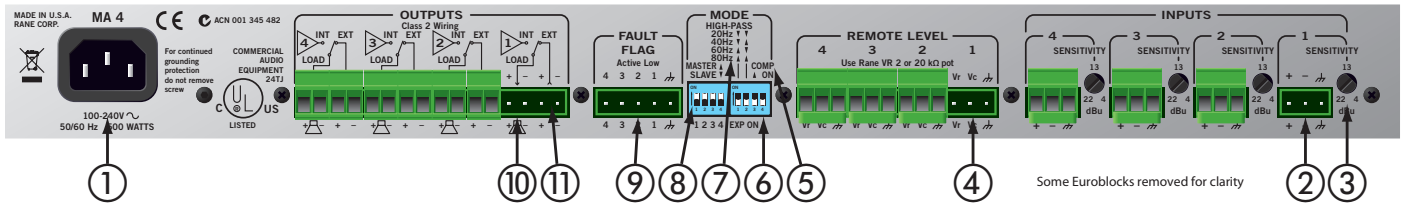

- ① Universal voltage, power-factor corrected, switch mode power supply operates 85 to 260 VAC, 50 Hz or 60 Hz. The supply features under and over voltage protection, low inrush current and operates with up to 85% efficiency.
- ② INPUTS are balanced and accept up to +22 dBu via Euroblock connectors with strain-relief.
- ③ SENSITIVITY controls allow continuous adjustment from +22 dBu to +4 dBu. Integrated limiter prevents clipping regardless of input level and sensitivity setting.
- ④ REMOTE DC LEVEL control ports with Euroblock strain-relief connectors allow audio taper attenuation using optional VR 2 remote (or use 10k to 100k  $\Omega$  linear pot). Clickless muting may be implemented using a switch, connecting Vr to Vc.
- ⑤ A soft knee COMPressor is provided with rms threshold relative to the limit threshold. ON/off setting affects all channels. This allows uncompressed operation with typical program material while reducing continuous sine-wave power. Ratio is 3:1; Attack is 1.5 seconds; Decay is 3 dB per second; Soft knee span is 10 dB.
- ⑥ Downward EXPander reduces noise in the absence of signal. ON/off setting effects all channels.
  - RMS Threshold: -70 dBFS; Ratio: 3:1; Attack: 50 ms; Gain reduction: 10dB/sec.
- ⑦ Selectable 20 Hz, 40 Hz, 60 Hz or 80 Hz HIGH-PASS filters are provided. The setting affects all channels. Filters are 12 dB per octave, Butterworth alignment.
- ⑧ Each channel is set for MASTER or SLAVE operation. Master channels write Fault Flag status. Slave channels read Fault Flag status.
  - The Master setting is used for remote fault reporting and/or automatic redundancy switching control.
  - The Slave setting is used for individual channel remote power sequencing or automatic redundancy switching.
- ⑨ Individual FAULT FLAG ports are provided for each channel.
  - The Fault Flag uses high-side active drive and passive pull down. No fault = +5 volts. Fault = 0 volts.
  - Channels set to Master drive the Fault Flag high when no fault is present. Passive pull down pulls the Fault Flag low when a fault occurs or power is lost.
  - Slave channels read the status of the Fault Flag.
- ⑩ Amplifier outputs are floating (not ground referenced) and are **not** bridgeable. Each channel delivers 100 watts into a 4 or 8 $\Omega$  load. Average load impedance is estimated then used to determine the limiter threshold required to limit maximum power to 100 watts and peak current to less than 7.5 amps. Impedance estimation requires a minimum of 3.3 watts and is averaged over 180 ms.
- ⑪ External amplifier input is used for Internal, automatic redundancy switching.
- ⑫ Comprehensive front panel metering is included for each channel:
  - Four segment, load sensitive headroom meter shows remaining headroom.
  - Limiter, Compressor and Expander indicators light when the associated dynamics control is active.
  - The Fault indicator lights when a fault is detected
  - The Load indicator is *off* when impedance is above 16 $\Omega$ , *on* when impedance is between 2 and 16 $\Omega$  and *flashing* when the impedance is below 2 $\Omega$ .
  - The Ready indicator is *off* when the power switch is off, *flashing* when the power switch is ON and the unit is in standby (Slave channel with high fault flag) and *on* when the channel is active.

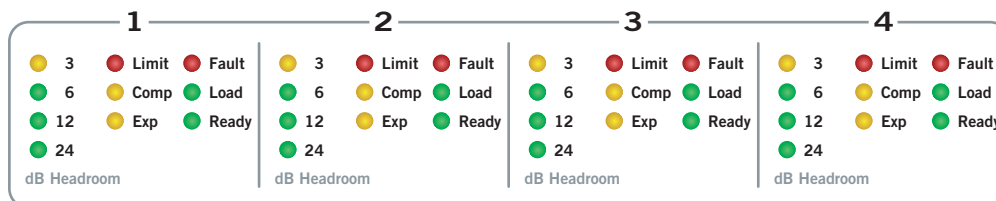

# MA 4

## MULTICHANNEL AMPLIFIER



### Block Diagram

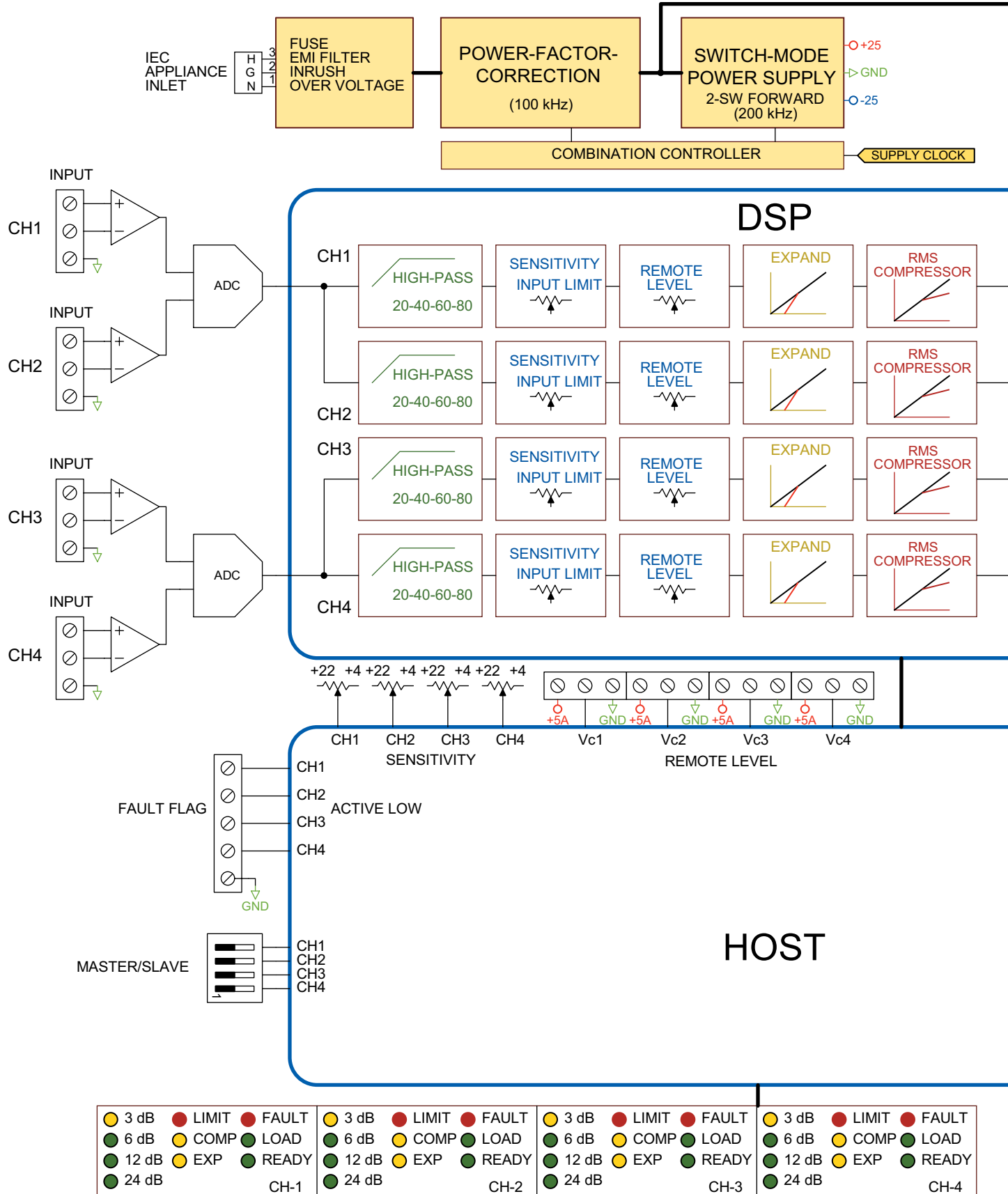

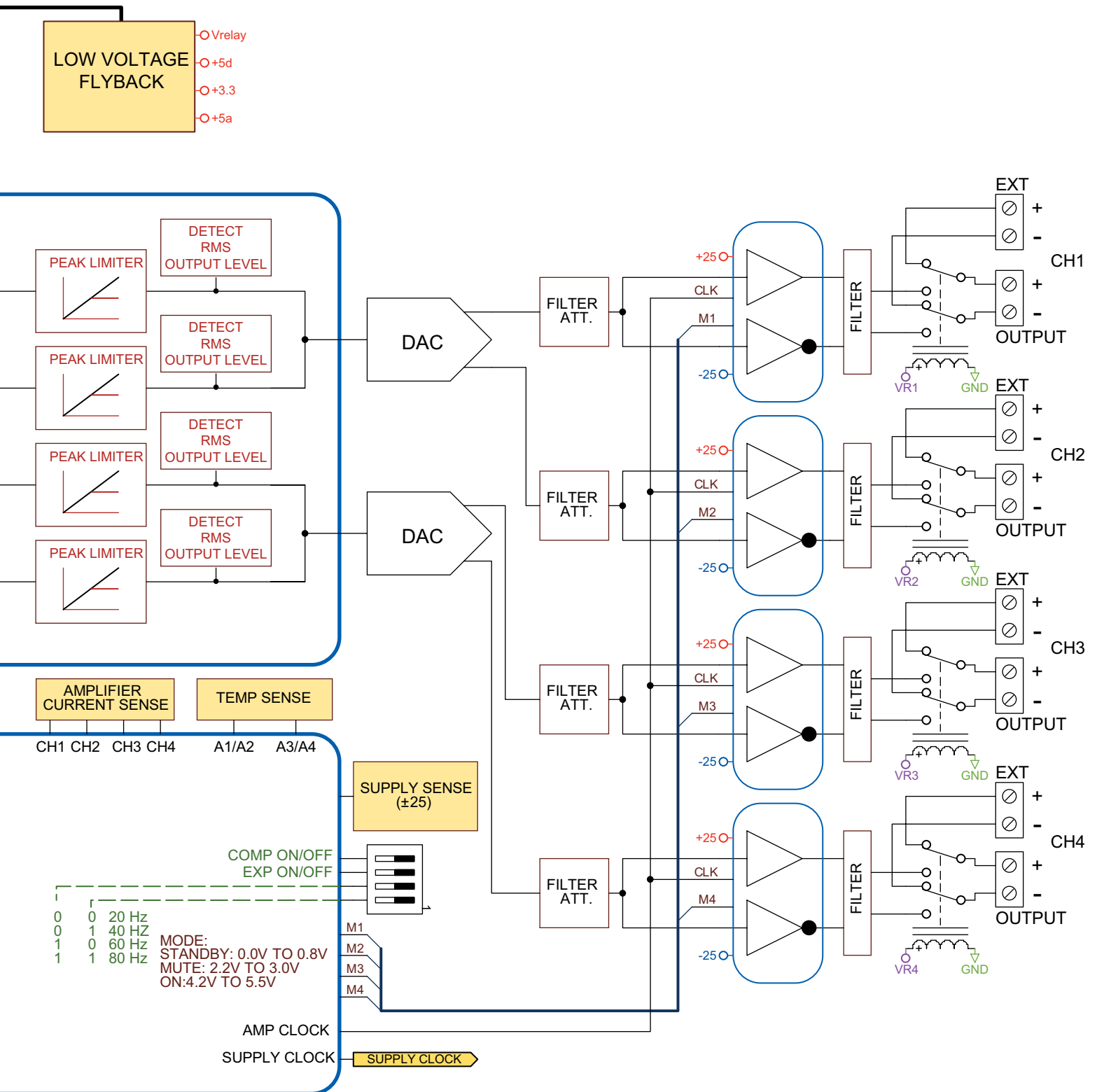

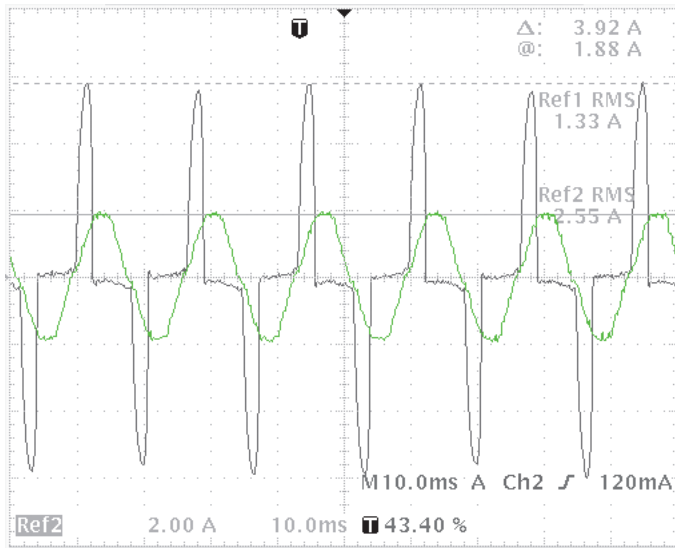
**Power-Factor-Correction (PFC)**

Near perfect Power-Factor with  $\frac{1}{3}$  the peak current and  $\frac{1}{2}$  the average current (green) compared to non power-factor-corrected supply with conduction of 3 ms (black). The response is measured at 100 watts.

**Architectural Specifications**

The unit shall be a four channel amplifier. It shall deliver 100 watts of power per channel into a 4 to 8 ohm load. The amplifier shall incorporate load sensing with normal operation in the range of 2 to 16 ohms. Front panel indicators shall alert presence of a channel load outside of this range.

The amplifier shall have balanced inputs with Euroblock connectors and Euroblock output connectors capable of accepting 12 gauge wire. Sensitivity controls with a range of +22 to +4 dBu shall be provided for each input on the rear panel by means of screwdriver adjustment. Load sensitive headroom meters shall provide indication of 3, 6, 12 and 24 dB of remaining headroom.

Euroblock connectors shall be provided as a means of connecting remote DC level potentiometers or switches to attenuate the input level of each channel.

Automatic redundancy switching shall be provided in the event of a fault of any amplifier channel. Euroblock connectors shall provide a means of connecting additional amplifier outputs for automatic backup purposes. Each channel shall have master or slave operation determined by a rear panel dipswitch. Master channels shall write fault flag status, and Slave channels shall read fault flag status.

A rear panel dipswitch shall provide a selection of 20, 40, 60 or 80 Hz highpass 2<sup>nd</sup>-order Butterworth filters. Load sensitive limiter circuits shall prevent clipping and the associated loss of speech intelligibility. A front panel LED shall indicate limiter activity within each channel.

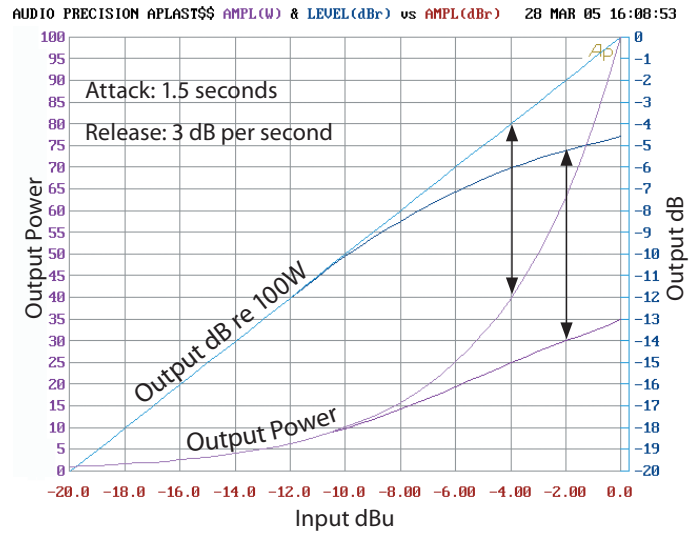
**Compressor Response**

Built-in compressors shall be provided with a 10 dB threshold. A rear panel dipswitch shall activate or deactivate the compressors. A front panel LED shall indicate compressor activity within each channel.

Built-in expanders shall be provided with a -70 dBFS threshold. A rear panel dipswitch shall activate or deactivate the expanders. A front panel LED shall indicate expander activity within each channel.

Euroblock connectors on the rear panel shall provide a means of transmitting or receiving fault flag information to other amplifiers or indicators with an active 5 volt drive. A front panel LED shall indicate a fault flag condition within each channel.

Thermal management shall employ forced air cooling, allowing the amplifiers to operate reliably in ventilated racks at 40°C ambient temperature. The fan speed air flow shall be controlled by temperature. Intake shall be on the left side of the chassis and exhaust on the right side, incorporating low velocity air flow to minimize noise within a rack cabinet.

The universal internal switch-mode power supply shall operate from 100 to 240 VAC, 50 or 60 Hz. The power supply design shall provide power-factor-correction with very low inrush current and overvoltage protection. An IEC connector and IEC cord shall be utilized. A front panel mounted power switch shall be provided.

*The unit shall be a Rane Corporation Model MA 4.*

## Basic Application

Don't let those extra connections and switches intimidate you.

The MA 4 is a high-quality general-purpose amplifier and connects like any other.

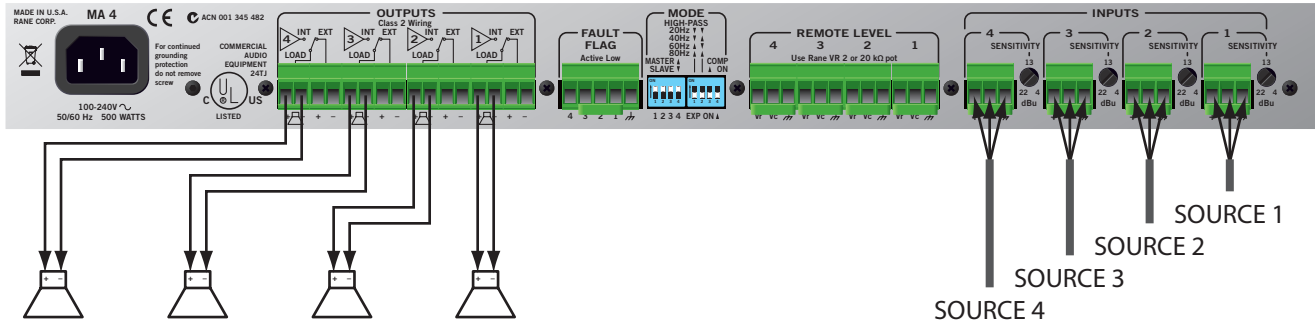

## Advanced Application - Remote Turn-on

If you wish to operate an amplifier channel in low power standby with remote turn-on, set its rear panel switch to SLAVE.

External +5 volts connected to the FAULT FLAG holds the amplifier in standby.

Floating the FAULT FLAG or connecting it to ground turns the channel on.

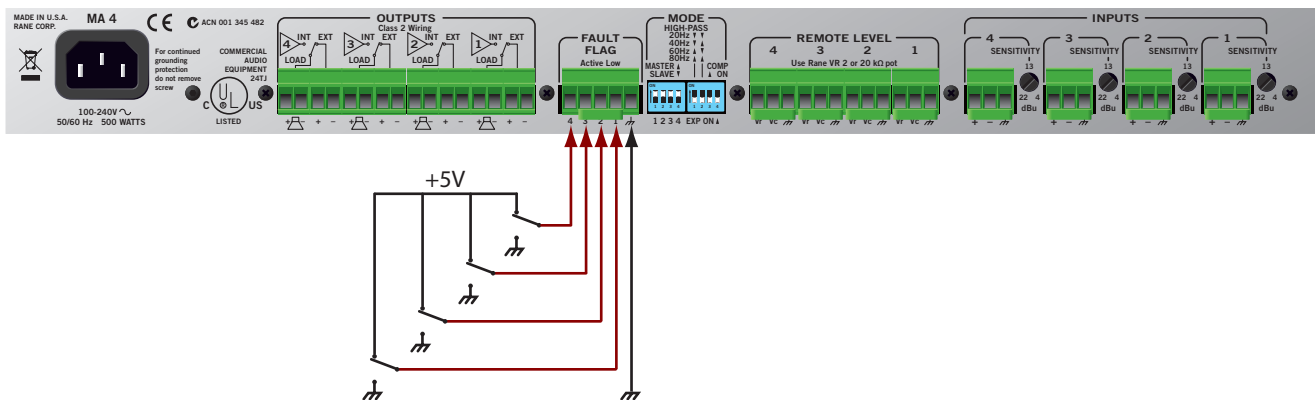

### Advanced Application - Fault Reporting

If you wish to have an amplifier channel report a fault to a control system or back up amplifier, set it to Master. The Fault Flag is held high (+5 volts) during normal operation and goes low (passive pull down) when a fault occurs. For information about Fault Flag operation (applications and reported faults) see the Manual, page 3.

Remote Level Control inputs are provided for each channel. The Rane VR 2 or any 10k to 100 kΩ potentiometer may be connected to these inputs.

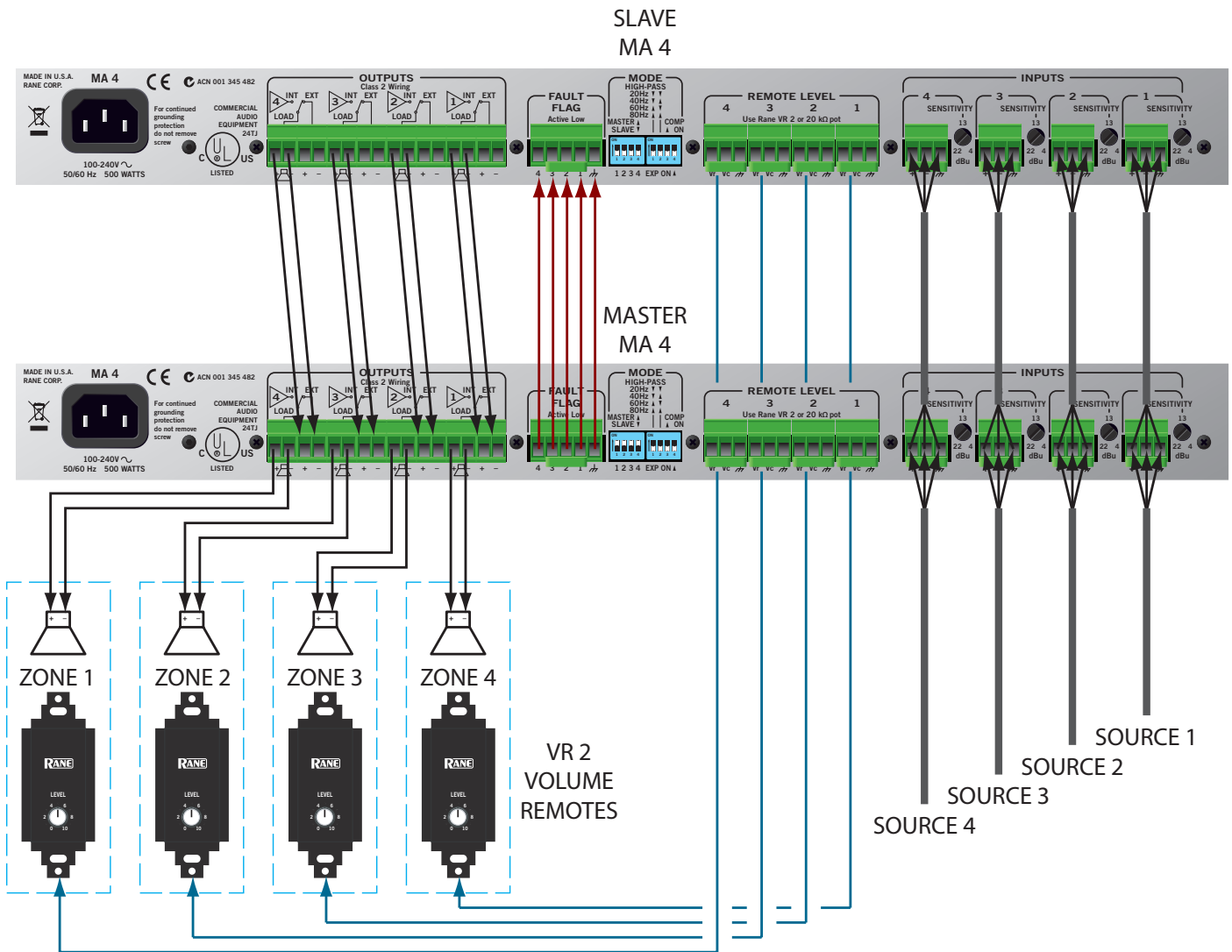

### References

1. D. Bohn, "Constant-Voltage Audio Distribution Systems," *RaneNote*, (2000).