

## General Description

You do the math. Any way you add it up, Rane makes the finest crossovers. There is no easier or smarter way to biamp your system than with the SAC 22 Crossover.

The SAC 22 employs state-variable 4th-order Linkwitz-Riley filter alignments to minimize phase difficulties in the critical crossover region. Simply put, a Linkwitz-Riley crossover exhibits identical phase characteristics on its Low pass and High pass Outputs. This characteristic guarantees in-phase outputs at all frequencies. In-phase outputs are mandatory for proper acoustic summing of common signals from adjacent drivers in the crossover region. An added benefit of this topology is steep 24 dB per octave rolloff slopes. A slope of this magnitude guarantees drivers designed to produce a specific range of frequencies, and no more, will not be driven past their limits, thereby minimizing distortion and driver fatigue. For deeper information, see the Rane-Note, "Linkwitz-Riley Crossovers" available at the Rane website.

The SAC 22 utilizes a 31-position precision DC control voltage potentiometer to select the Low/High Frequency point. This crossover circuit design assures consistent accuracy from channel-to-channel and unit-to-unit. This is a distinct advantage over continuously variable designs using ganged potentiometers which can yield large variations in channel-to-channel matching.

The Mono Subwoofer output provides a separate mono sum of the Left and Right Low Outputs. A 100 Hz low pass filter may be activated for this Output. The Subwoofer Output may be used along with the Left and Right Low Outputs.

The Input Level allows decreasing the overall sensitivity of the entire sound system, including the mono subwoofer if one is used. The Low Level, High Level and Mono Subwoofer Output Level controls allow compensation for sensitivity variations in amplifiers and drivers.

The SAC 22 features balanced XLR connectors.

## Features

- Precise Channel Matching with Single Set of Controls
- 31-Position Frequency Selector
- High and Low Output Level Controls
- +4 dBu and Overload Indicators
- 24 dB/Octave Linkwitz-Riley Filters
- Separate Mono Subwoofer Output
- Balanced XLR Connectors
- Internal AC Power Supply Meets CE Requirements



**Features and Specifications**

Parameter	Specification	Limit	Units	Conditions/Comments
Crossover:				
.....Alignment	Linkwitz-Riley			Proprietary 4th-order state variable
.....Slope	24 dB per octave			
.....Range	100 Hz-3.2 kHz			
.....Control	Stereo			31-detent continuously variable DC
.....Tracking	2	max.	%	Channel-to-channel tracking error
.....Accuracy	10	max.	%	Frequency selector error
Inputs: Type	Active Balanced			
.....Connectors	XLR			Pin 2 "hot" per AES standards
.....Impedance	20k	1%	Ω	Each leg
.....Maximum Level	+20	1	dBu	
.....Gain Range	Off to +6	±0.5	dB	
Outputs: Type	Active Balanced			
.....Connectors	XLR			Pin 2 "hot" per AES standards
.....Impedance	100	1%	Ω	Each leg
.....Maximum Level	+20		dBu	2 kΩ load
.....Gain Range	Off to +0	1	dB	
Mono Sub:				
.....Filter	100 Hz Low Pass	±3%		3rd-order Butterworth - 12 dB/octave
.....Gain Trim	Off to +0		dB	
RFI Filters	Yes			
Infrasonic Filters	15 Hz, 18 dB per octave	3%		Butterworth
Frequency Response	15 Hz-40 kHz	+0/-3	dB	R load > 2 kHz
THD+Noise	0.1	typ.	%	+4 dBu, pass band
Signal-to-Noise Ratio	84	min.	dBr	Max. gain re +4 dBu, 20 kHz BW
Unit: Agency Listing				
.....120 VAC model	UL			UL 6500 (file E104174)
	cUL (Canada)			C22.2 (file E104174)
.....230 VAC model	CE-EMC EN55013, EN55020			EMC Directive 89/336/EEC
	CE-Safety EN60065			LV Directive 73/23/EEC
Unit: Construction	All Steel			
.....Size	1.75"H x 19"W x 5.3"D (1U)			(4.4 cm x 48.3 cm x 13.5 cm)
.....Weight	5 lb			(2.3 kg)
Shipping: Size	4.25" x 20.3" x 13.75"			(11 cm x 52 cm x 35 cm)
.....Weight	8 lb			(3.6 kg)
<i>Note: 0 dBu = 0.775 Vrms</i>				

**SAC 22 Block Diagram**

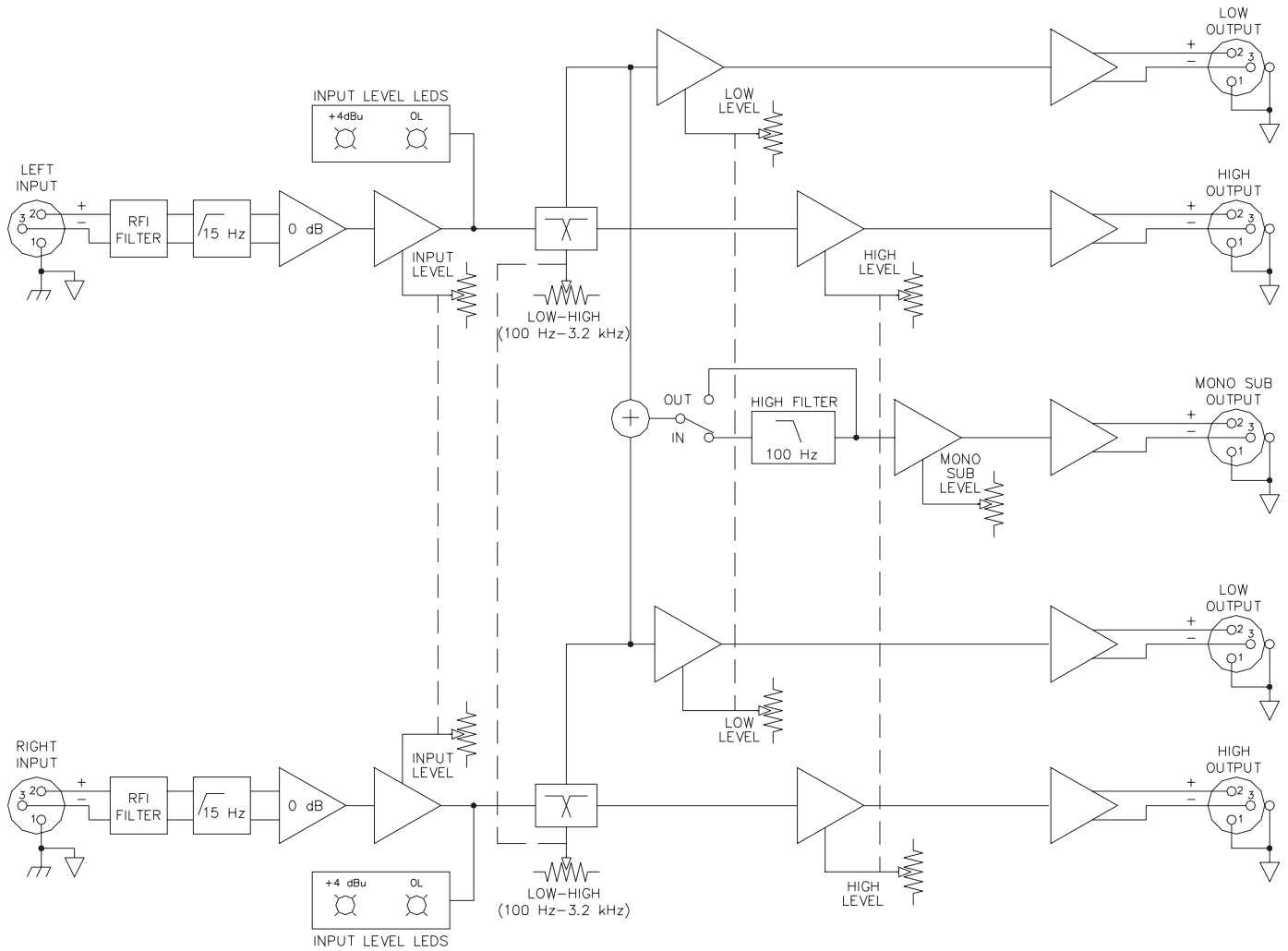

# SAC 22

## STEREO 2-WAY ACTIVE CROSSOVER



### Rear Panel

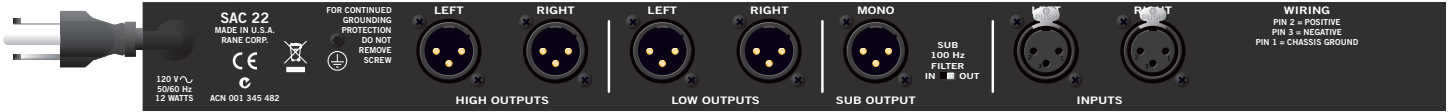

### Architectural Specifications

The active crossover shall be of stereo 2-way design with an additional mono subwoofer output. The crossover shall contain 4th-order Linkwitz-Riley filters. The crossover frequency shall range from 100 to 3200 Hz, controlled by a variable control with 31 detents to allow mechanical reference of crossover setting. The active crossover shall afford an input level range of Off to +6 dB. The output level controls shall afford a level range of from Off to +0 dB. Both channels shall be operated by a single set of controls.

LEDs shall indicate both +4 dBu and overload conditions. Inputs and outputs shall be of active balanced design terminated with XLR connectors. RFI filters shall be provided.

The unit shall be capable of operation by means of its own built-in power supply connected to 120 VAC (240 VAC where applicable) and meet CE requirements. The unit shall be entirely constructed from cold-rolled steel.

*The unit shall be a Rane Corporation SAC 22 Active Crossover.*

### Optional Accessory

- SC 1.7 Security Cover